

# ***MICROMAX* 6000 TFC**

## **Owner's Manual**

This manual is for the Installation, Operation, and Maintenance of the *MICROMAX* 6000 TFC Reverse Osmosis (RO) Drinking Water Appliance

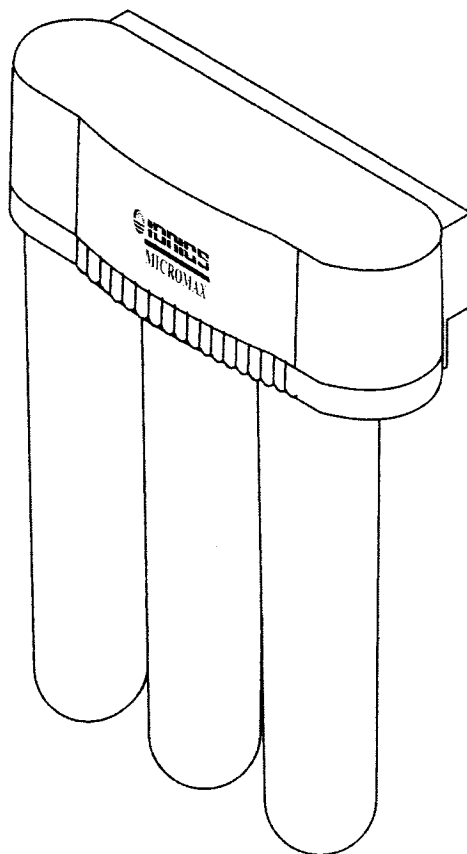

Ionics U.S. Water Group  
1971 Rutan Drive  
Livermore, CA 94551-7646  
925-456-7000  
925-456-7010 Fax  
[www.ionicsfidelity.com](http://www.ionicsfidelity.com)

**INSTR7034 0305**

# INTRODUCTION

This manual explains the installation, operation and maintenance of the Ionics U.S. Water Group Reverse Osmosis (RO) Drinking Water Appliances. Please read each section of this manual carefully. The specific model chosen should be appropriate for the local water conditions and the customer's needs. Check the Performance Data Sheet for the performance characteristics and the conditions of use.

The undercounter RO drinking water appliances are designed to connect permanently to a home plumbing system. To ensure that the installation conforms to your state and local plumbing codes, it is recommended that the installation be performed by a qualified installation specialist for RO drinking water appliances or a licensed plumber. Failure to install the system as instructed will **VOID** the warranty.

**Caution: The RO membrane cartridge may be shipped with a preservative solution inside.  
Make sure to flush it thoroughly as directed before the first use.**

## TABLE OF CONTENTS

### I. Installation Instructions

A. Determine the appliance location .....	3
B. Prepare the area for installation .....	3
C. Prepare the appliance for installation .....	4
D. Make the faucet mounting hole .....	4
E. Mount the faucet .....	5
F. Install the feed water valve.....	6
G. Prefill and sanitize the storage tank .....	6
H. Install the drain connection .....	6
I. Install the purification assembly and storage tank .....	7
J. Make the tubing connections .....	7
K. Install the icemaker hookup (optional).....	7
L. Start up the appliance .....	8
M. Flush the appliance of the preservative and check the operation .....	8
N. Cleanup, paperwork and customer orientation .....	8
O. Installation troubleshooting .....	9

### II. Operation & Maintenance Instructions

A. Important water quality assurance requirements .....	10
B. Replacing the filter cartridges .....	10
C. Replacing the RO membrane cartridge .....	11
D. Sanitizing the RO appliance .....	11
E. Long term non-use .....	12

# I. Installation Instructions

## A. DETERMINE THE APPLIANCE LOCATION

The appliance can be located under a sink or in a basement depending on space availability and the customer's preference. If a basement installation is selected, additional tubing, hardware and fittings may be needed and a hole will have to be made from inside the cabinet, through the floor, to the basement. Never install it in an area of the home where the temperature may drop to freezing, damage to the appliance may occur.

The exact placement of the various components of the appliance will vary from installation to installation. The installer, in conjunction with the customer, must decide on where to place the faucet, tank and purification assembly by balancing the homeowner's convenience with ease of installation and servicing. (See Fig. 1).

Considerations for an icemaker or other remote hookup should be predetermined, including routing and any additional tools, fittings, and tubing that may be required.

Installation must comply with state and local plumbing codes.

## B. PREPARE THE AREA FOR INSTALLATION

To save time, it is often advised to call the customer and request that they clean under the sink prior to arrival. Otherwise, remove supplies from under the sink and stack them neatly away from the working area. Arrange a light for the work area, if necessary.

Inspect the cold water supply line and determine if any special fittings, in addition to what is included in the kit, are required.

**NOTE:** It is a good idea at this time to check the condition of the undercounter plumbing for any existing or potential leaks. The customer should be advised of any problem so there is no misunderstanding as to who is responsible.

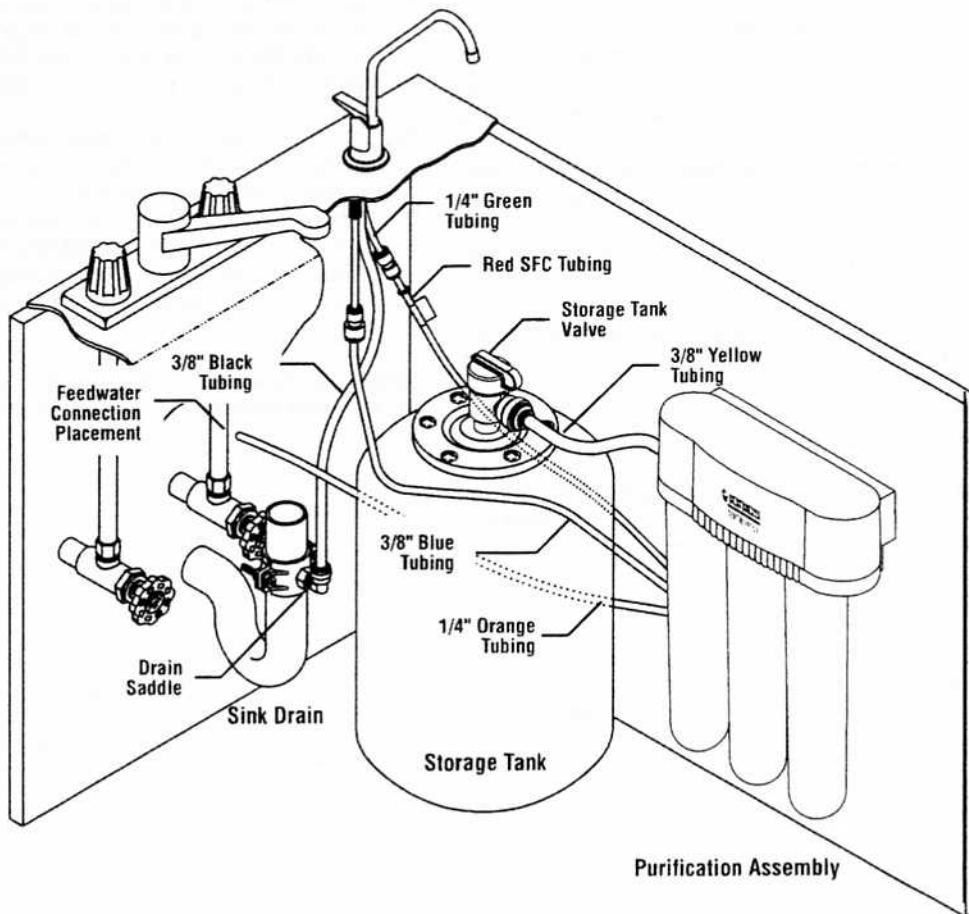

Fig. 1

## C. PREPARE THE APPLIANCE FOR INSTALLATION

Open the shipping carton and remove the components. Check to see that all of the installation parts are present. They should include the purification assembly, storage tank, faucet, installation hardware, RO membrane cartridge and tubing. Check to see that the air charge in the empty tank is approximately 7 psi (48 kPa). **Note:** Check the storage tank air pre-charge with the tank valve open. Adjust it if necessary. If the optional percent rejection monitor is selected, the probes should be installed at this time. Follow the instructions that came with the monitor. To ensure you the highest level of purity, the RO membrane cartridge has been shipped separately in a sealed plastic bag. Follow the steps below to install the RO membrane cartridge.

**STEP 1:** Cut open the sealed plastic bag and remove the RO membrane cartridge.

**STEP 2:** Remove the white plug from the fitting at the bottom of the cartridge by pushing in the small white collet and pulling out the plug simultaneously. (See figure 6.)

**STEP 3:** Remove the red plastic cap from the top of the cartridge.

**STEP 4:** Connect the red SFC reject tubing by inserting it into the fitting at the bottom of the RO membrane cartridge as far as it will go. Line up the cartridge ears (see figure 9), insert the cartridge and push it into the head until it is fully seated. Twist the cartridge 1/4 turn to the right to lock it into place. The final orientation should be such that the cartridge label faces toward the front and the fitting is located towards the rear.

## D. MAKE THE FAUCET MOUNTING HOLE

A wide variety of RO faucet mounting situations may be encountered. The most common are stainless steel or ceramic on metal sinks. Consult your dealer for any other materials which may be encountered.

The customer should be consulted before determining the faucet location. The faucet should be positioned so that it empties into the sink and the spout swivels freely for convenience.

If the sink already has a hole provided that can accommodate the RO faucet, then no drilling is required.

**NOTE:** With customer's permission, sprayers can be disconnected to provide a suitable mounting hole for the RO faucet.

**IMPORTANT:** It is mandatory that safety glasses be worn during the sink hole drilling operations in order to prevent eye injury.

Before drilling the hole, always check underneath the sink to ensure that nothing will interfere with mounting the faucet such as reinforcing ribs, support brackets or the cabinet construction.

**Stainless steel sink, air gap faucet.**

Recommended tools:

- Center punch
- Variable speed drill and high speed drill bits
- Greenlee 7/8" chassis punch (alternate 9/16" may be used for a non-air gap faucet)
- Protective gloves

**Procedure:**

- 1) Center punch a small indent at the center of the desired faucet location.
- 2) Slowly drill the required pilot hole for the chassis punch.
- 3) Set up the chassis punch per the instructions and tighten the nut to cut the desired hole size.
- 4) Clean up all sharp edges with a file if necessary.

**Porcelain/Enamel/Ceramic sink** on sheet metal or cast iron base; air gap or non air gap faucet.

Recommended tools:

- Variable speed drill
- Relton 7/8" porcelain cutter tool set
- Plumber's putty

It is important to understand what is involved in this procedure. First, the glassy layer of porcelain must be penetrated through to the base metal. Second, a center disc of porcelain must be removed while protecting the surrounding porcelain against chipping or fracturing. Third, the base metal must be drilled through to complete the hole.

**Procedure:**

- 1) Mark the center for the 7/8" hole.
- 2) Form a shallow putty dam around the hole area and fill it with enough water to lubricate the carbide drill bit.
- 3) Carefully drill a pilot hole through the porcelain/enamel and the base metal using a carbide type pilot drill. **Important: Always operate the drill with light pressure at a slow speed (300-400 rpm).**
- 4) Insert the pilot tip of the spring-loaded porcelain cutter into the pilot hole.
- 5) Drill the porcelain/enamel using the spring-loaded porcelain cutter, making certain a complete ring has been cut through the porcelain/enamel to the metal base.
- 6) Change to the metal cutter. With a slow speed and light pressure, cut away the inner porcelain/enamel disc down to the base metal. Make certain that the cutter does not touch the outer rim of the cut porcelain/enamel. Continue with this bit to cut completely through the metal.

**IMPORTANT: When using a porcelain cutter it is critical that it is always in a sharpened condition. Dull cutters have been known to chip sinks.**

## E. MOUNT THE FAUCET

Undercounter installations generally require that the faucet's built-in air gap be used. In basement installations, the built-in air gap does not have to be used if one is provided elsewhere on the drain line.

### Undercounter Installation With An Air Gap Faucet:

- 1) Familiarize yourself with all of the components shown in the air gap faucet diagram. (See Fig. 2)
- 2) Remove the hardware from the threaded nipple of the faucet, except for the chrome base plate and the rubber washer. The rubber washer may be replaced with a bead of plumber's putty for a neater appearance.
- 3) Connect the 1/4" green tubing supplied in the installation kit to the smaller barb on the air gap faucet. Push it on firmly until it seats.
- 4) Connect the supplied 3/8" black tubing to the larger barb on the air gap faucet. Push it on firmly until it seats.
- 5) From above the sink counter-top, feed the air gap tubing and the

threaded nipple through the faucet mounting hole and position the faucet spout over the sink.

- 6) From below the sink/countertop, install the white spacer (open side toward the air gap tubing), flat washer and hex nut onto the threaded nipple and tighten it by hand.
- 7) Back off on the hex nut just enough to slide the slotted washer (open side toward the air gap tubes) between the white spacer and the underside of the sink/countertop.
- 8) After rechecking the faucet orientation, tighten the hex nut with a 9/16" wrench until the faucet feels secure.
- 9) From above the sink, make any minor orientation corrections by turning the faucet on its flats with a padded adjustable wrench. Use care not to mar the finish.

Faucet with Air Gap

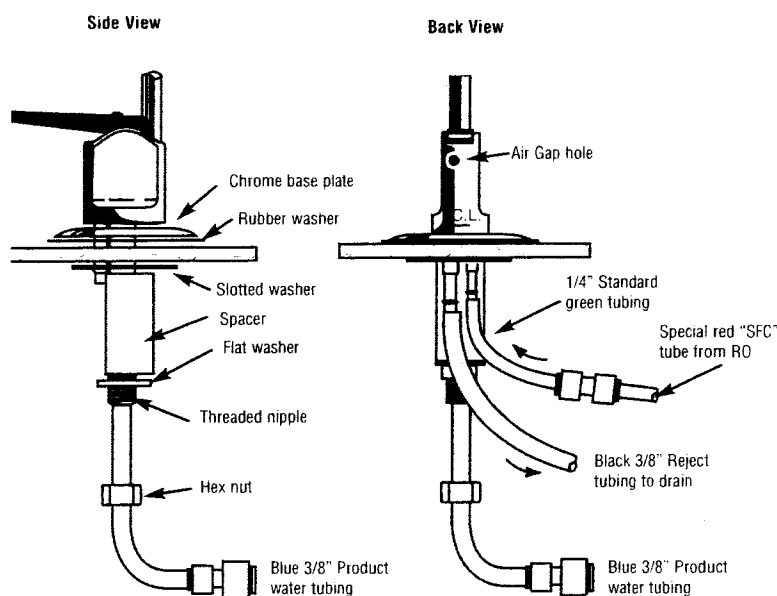

Fig. 2

**F. INSTALL THE FEED WATER TAPPING VALVE AND TUBING**

- 1) Consult the manufacturer's installation instructions.
- 2) Connect one end of the orange tubing to the feedwater valve.

**G. PREFILL AND SANITIZE THE STORAGE TANK**

Prefilling the storage tank is always recommended so that there is pressure to check for leaks as well as sufficient water to flush the carbon postfilter. The RO Drinking Water Appliance is furnished with a container of special sanitizing granules. It is important to use a sanitizer when prefilling the tank so the solution can sanitize the tubing, fittings, and the faucet at start up.

- 1) Thread the taped 3/8" x 1/4" tank fitting into the tank valve. Do not over tighten. Open the tank valve so that the tank valve handle is parallel to the valve body. Locate the enclosed container of sanitizing granules, open it and pour the contents into the end of the tank valve.
- 2) Disconnect the 3/8" yellow tubing from the back of the purification assembly and connect one end of it into the tube fitting located on the tank valve.
- 3) Connect the other end of the 3/8" yellow tubing to the 3/8" x 1/4" union connector included in the tank sanitization kit.
- 4) Connect the free end of the 1/4" orange feedwater tubing to the other end of the 3/8" x 1/4" union connector.
- 5) Open the feedwater valve (making sure the tank valve is still open) and allow the tank to fill (about 3 minutes).
- 6) Close the feedwater tapping valve and the tank valve fitting. Set the tank aside while proceeding with the rest of the installation (the sanitizing solution should be kept in the tank for at least 15 minutes).

**NOTE:** If you encounter difficulty in removing the tubing from the tank, make sure the tank valve is closed and then cut the yellow tubing approximately 1" away from the tank valve fitting to relieve the pressure. Remove the 1" piece from the tank fitting.

**NOTE:** If an alternate storage tank is used, it should be sanitized with unscented household bleach (5-1/4%). Use 3 ml. (1/2 teaspoon) of bleach for a 2.5 gallon tank.

- 7) Reconnect the 3/8" yellow tubing to the back of the purification assembly.

**IMPORTANT:** After the installation is complete, it is recommended that the 3/8" x 1/4" union connector be saved for future use in tank sanitization.

**H. INSTALL THE DRAIN CONNECTION**

**IMPORTANT:** Before starting this procedure, inspect the condition of the drain piping, especially in older homes where the traps and tailpieces can be deceptively thin and frail. If they are in poor condition, it is wise to inform the customer that the condition should be remedied.

**IMPORTANT:** Some local plumbing codes may prohibit the use of saddle-type valves and/or drain connections. The use of saddle-type valves are prohibited in Alaska, Delaware, Idaho, Kentucky, Massachusetts, Michigan, Minnesota, New Hampshire, North Dakota, Ohio, and South Dakota. Check your local plumbing codes for any restrictions that apply. Massachusetts CMR 248 strictly prohibits the use of saddle-type valves. The feedwater connection must conform to applicable plumbing codes.

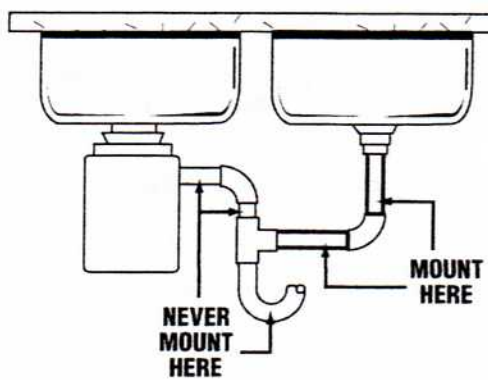

Fig. 4

**Undercounter Installation:**

The drain saddle is designed to fit around a standard 1-1/2" OD drain pipe. For smaller (lavatory type) or larger (ABS pipe) drains, consult your dealer for special drain saddles.

The drain saddle should always be installed above (before) the trap and on the vertical or horizontal tailpiece. Never install the drain saddle close to the outlet of a garbage disposal because plugging of the RO drain line may occur. (See Fig. 4)

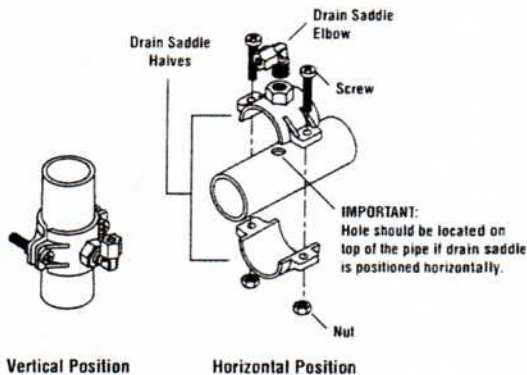

Fig. 5

- 1) Position the threaded half of the drain saddle at the selected location and mark the pipe through the threaded opening.
- 2) Drill a 1/4" hole at the marked location through one side of the drain tailpiece.
- 3) Position both halves of the drain saddle on the drain pipe so that the threaded opening is lined up with the hole in the drain pipe.
- 4) Use the screws and nuts to clamp the drain saddle onto the drain pipe. Make sure that there is equal space between saddle halves on each side. Do not overtighten. (See Fig. 5)
- 5) Orient the elbow in the direction of the RO faucet location.

## I. INSTALL THE PURIFICATION ASSEMBLY AND STORAGE TANK

### Undercounter Installation:

The purification assembly is usually mounted to the right or the left side wall inside of the sink cabinet, taking into consideration the space available and the tank location. Generally, the storage tank is placed in the rear of the sink cabinet while the purification assembly is positioned toward the front for filter cartridge accessibility.

To mount the purification assembly, elevate it at least 2" (5 cm) off of the cabinet floor and, while keeping it level, mark the location of the mounting holes on the cabinet side wall. Make small pilot holes with an awl or a drill and screw in the two mounting screws; leaving just enough protruding to allow the bracket mounting slots to slide over them.

**NOTE:** If the cabinet side walls are not of solid construction, the purification assembly can be set on the cabinet floor and held against the side wall with the mounting screws. However, the purification assembly will then need to be lifted from the mounting screws in order to remove the filter cartridges.

The storage tank may be oriented either vertically or horizontally. It is generally placed to the rear of the cabinet but can be set in the front center (between the sink basins) for ease of access if space permits.

## J. MAKE THE TUBING CONNECTIONS

With all of the components in place, the tubing connections can be made. When routing the tubing between the components, several guidelines should be observed.

- Tubing runs should generally follow the contour of the cabinet rather than interfere with the cabinet storage area.
- Strive for a neat and orderly tubing "flow" by using fasteners (e.g. insulated staples) to secure the tubing.
- Arrange the tubing so that there are no sharp bends. Leave some "play" in the tubing for ease of servicing, then cut the tubing to the desired length.
- Try to keep the tubing from the purification assembly to the tank and faucet as short as practical for good flow.

### Undercounter Installation:

The appliance will have the 3/8" yellow, 3/8" blue and the 1/4" orange tubing already connected to the purification assembly.

- 1) The 1/4" orange tubing should already have been connected to the feedwater valve. Route the other end through the large opening in the bottom of the metal bracket and loop it back to the "Feed" connection on the purification assembly.
- 2) Attach the 1/4" x 3/8" union to 1/4" blue tubing on faucet.
- 3) Connect the 3/8" blue tubing from the purification assembly to the other end of 3/8" x 1/4" union.
- 4) Route the 3/8" black tubing from the faucet air gap to the drain saddle so that it slopes continuously downward without any loops or low spots. Cut the tubing to the proper length and connect it to the drain elbow.
- 5) Connect the 3/8" yellow tubing from the purification assembly to the tank.
- 6) Route the special red SFC tubing toward the faucet. **Do not cut this special SFC tubing.** It's length is important to maintain proper efficiency and performance.
- 7) Cut the 1/4" green tubing from the faucet air gap to the proper length and connect it to the 1/4" connector fitting on the end of the SFC tubing.

## K. INSTALL THE ICEMAKER HOOKUP (optional)

The RO drinking water appliance can be connected to any standard refrigerator icemaker or icemaker/water dispenser. It should never be connected to a commercial type bar icemaker.

Hooking up an icemaker involves connecting a tee with a shut off valve into the 3/8" blue faucet tubing and routing the tubing over to the refrigerator. Hooking up to existing copper unit is generally not recommended unless it is less than six months old. If copper tubing must be used, then the installation of a small in-line carbon filter at the refrigerator connection is recommended.

Before turning off the existing tap water supply to the refrigerator icemaker, always shut off the icemaker first (usually by lifting the lever arm above the bin to the uppermost position). The icemaker should only be turned on again **after** the RO system has been drained several times and the storage tank has a **full** supply of water.

**NOTE:** Contact your dealer for the availability of special icemaker hookup kits.

**IMPORTANT:** Before any service is performed on the RO appliance, always turn off the icemaker valve and the icemaker unit. Only turn them on when the system is operating and the tank is full.



## L. START UP THE APPLIANCE

- 1) Double check to see that all of the connections are secure.
- 2) Open the feedwater valve and check the appliance for leaks. If any leaks are detected, close the valve and correct the problem before proceeding. **NOTE:** If a leak occurs at a "Push In" plastic fitting, then refer to Fig. 6.
- 3) Open the storage tank valve and lift the faucet handle until a steady stream of water flows. Close the faucet, wait at least five (5) minutes and carefully check for leaks. Correct them as necessary.

**NOTE:** When the appliance is first turned on, water may intermittently "spurt" from the air gap opening at the side of the faucet. This is perfectly normal, and is caused by air trapped in the system. This will usually disappear within a short time.

## M. FLUSH THE APPLIANCE OF THE PRESERVATIVE AND CHECK THE OPERATION

- 1) With the tank valve closed (the tank should still contain the sanitizing solution at this point), open the faucet (set the faucet handle in the "up" position) and feedwater valve. Water should begin to drip from the faucet within several minutes. Continue to flush the system for 1 hour. Water will steadily drip from the faucet at the time. During this procedure, the tank is being intentionally bypassed in order to thoroughly sanitize the tank and also flush the membrane of any preservatives.
- 2) After flushing for 1 hour, shut off the faucet. Open the tank valve, lift the faucet handle again and allow the tank to completely empty. When the tank is empty, the faucet will drip steadily. Measure and record the rate at which water drips from the faucet. Use a graduated cylinder (in milliliters) and a watch with a second hand to calculate the approximate production in gallons per day (milliliters per minute x 0.38 = gpd). Proceed to check the reject flow by disconnecting the tubing at the drain connection and measuring the drip as outlined above. The ratio should be a minimum of 2.5 (reject) to 1 (product). Repeat every 5 minutes until the rate is constant. At this point the tank should be empty.
- 3) Allow the system to operate in this condition for 24 hours to ensure water purity.

- 4) Close the faucet and check the appliance for leaks. Allow the tank to fill completely (it will take approximately 4 hours), then drain the tank again. The water should be discarded because it may contain some preservative/disinfectant solution.
- 5) The appliance should be ready to use as soon as the tank refills. If any objectionable taste is noticed after the second tankful is drained, instruct the customer to wait and drain the tank the following day. Only at this time should an icemaker be turned on if one is connected to the appliance.

## N. CLEAN UP, PAPERWORK AND CUSTOMER ORIENTATION

- 1) Clean up the work area thoroughly. This is important in leaving a good final impression with the customer.
- 2) Affix any special decals or stickers. Fill out the warranty card and return it. Be sure to record the house water pressure and the TDS for your service files.
- 3) Familiarize the family members with the general operation of their new RO drinking water appliance. In particular, note the following:
  - The faucet handle positions: down for momentary flow, and up for continuous flow. Also, note the moveable spout.
  - The location of the feedwater valve and the tank shut off valve as well as the procedure for turning them off.
  - Review the many uses of the water (cooking, soups, juices, ice cubes, baby formula, pets, plants, etc.).
  - Review the recommended maintenance schedule as determined by the local water conditions.

### 'Push-In' Tubing Connector

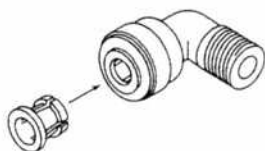

This product is outfitted with user friendly 'Push In' connectors. Proper use of the connectors is shown in the diagrams.

It is most important that the tubing selected for use with these connectors be of high quality, exact size and roundness, and with no surface nicks or scratches. If it is necessary to cut the tubing, use a plastic tubing cutter or sharp razor knife. Make a clean square cut.

Should a leak occur at a 'Push-In' connector, the cause is usually defective tubing.

- To Fix:
- Relieve pressure
  - Release tubing
  - Cut off at least 1/4" from end.
  - Reattach tubing
  - Confirm connection is leak free.

### To Attach Tubing

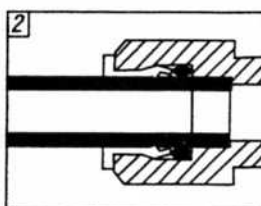
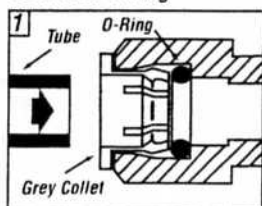

### To Release Tubing

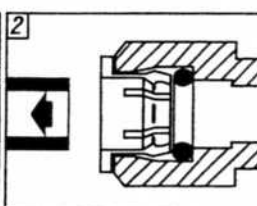
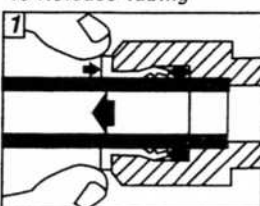

Push tubing straight in as far as it will go. Tubing is secured in

Push in grey collet to release tubing.

Pull tubing straight out.

Fig. 6



## O. INSTALLATION TROUBLESHOOTING

### **Problem: Leak at the drain saddle.**

**Cause:** Drain saddle not clamped tightly enough.

**Solution:** Tighten the drain saddle screws evenly and firmly.

### **Problem: Leak at the fittings threaded connection.**

**Cause:** Fitting is improperly taped or not tightened sufficiently.

**Solution:** Retape the threaded portion with Teflon® tape and thread it in firmly. Do not over tighten.

### **Problem: Leak at the fittings push-in connection.**

**Cause:** Tubing is defective if there is a tubing misassembly.

**Solution:** Remove the tubing. Squarely cut off 1/4 inch from the end of the tubing using a sharp razor knife and reinsert it into the fitting. Make sure that the tubing is pushed in completely until it seats. See Figure 6.

### **Problem: Leak at the filter cartridge head.**

**Cause:** Defective or misaligned O-ring.

**Solution:** Close the feedwater tapping valve and the storage tank valve. Lift up on the faucet handle and drain the tank a minimum of five (5) minutes. Remove the filter cartridge and check the condition of the O-rings. If they are misaligned, reseal them. If they are damaged, replace them.

### **Problem: The faucet leaks from the spout with the handle down.**

**Cause:** An obstructed or defective valve seat in the faucet mechanism.

**Solution:** Remove the faucet spout with a twisting/lifting motion and slide the faucet handle forward over the spout hole to gain access to the faucet valve. Unscrew the tee-bar and the slotted bushing to remove the valve. Clean out any obstruction or replace it with a new valve mechanism if necessary.

### **Problem: No steady drip from the open faucet after the tank is drained.**

#### **Causes:**

- The feedwater valve is not open.
- A leak from any product water fitting connection.
- The icemaker valve was left open before the start-up procedure completed.
- Air is still trapped in the system.

#### **Solutions:**

- Open the feedwater valve completely.
- Correct the fitting leak as outlined above.
- Close the icemaker valve and wait until the faucet drips.
- Wait for the air to be purged from the system.

### **Problem: Water leaks from air gap module opening.**

#### **Causes:**

- The drain line is blocked or the drain hole is not drilled through completely.
- Air is locked in the air gap outlet.
- There is excessive RO reject flow.

#### **Solutions:**

- Check to see that the drain line is clear of any obstruction and remove the drain saddle fitting to verify that the hole is drilled through completely.
- Blow air into the air gap outlet using a short length of tubing.
- Disconnect the red SFC reject tubing from the faucet air gap inlet tubing and check the reject flow rate. It should be less than 175 ml/min. If it is greater than 175 ml/min., replace the red SFC reject tubing with the new one of proper length.

### **Problem: Too little or no reject flow.**

#### **Causes:**

- Red SFC reject tubing is plugged or defective.
- The feedwater tapping valve is not open.
- An obstruction in the faucet air gap module.

#### **Solutions:**

- Replace the SFC reject tubing with one of proper length.
- Open the feedwater tapping valve completely.
- Remove the air gap module and inspect the internal flow path. Replace the air gap module if necessary.

### **Problem: Chlorine or other unpleasant taste/odor is evident after the initial tank filling.**

**Cause:** Residual preservative/sanitizer is still in the water.

**Solution:** Drain and fill the storage tank several times if necessary.

### **Problem: Noise in the drain (gurgling or dribbling sound).**

**Cause:** The reject water is dripping into the standing water in the drain trap.

#### **Solutions:**

- Make sure that the 3/8" black drain tubing from the faucet air gap module slopes continuously downward to the drain saddle without any loops or low spots.
- Angle the drain piping so that the reject water runs down the side of the drain pipe.
- Change the location of the drain saddle to the horizontal drain pipe or any alternate vertical drain pipe which is farther from the trap. Properly plug the original hole. **Caution:** Make sure the drain saddle is always installed above (before) the trap.

# II. Operation & Maintenance Instructions

## A. IMPORTANT WATER QUALITY ASSURANCE REQUIREMENTS

Reverse Osmosis drinking water appliances contain treatment components that are critical for the effective reduction of Total Dissolved Solids (TDS) as well as inorganic chemical contaminants. It is strongly recommended that the user test the water periodically (every six months minimum) to verify that the appliance is performing satisfactorily. Routine maintenance is necessary in the form of prefilter, postfilter, and membrane replacement, based on the following guidelines:

- Prefilter, and Carbon Postfilter: Change every six months to one year depending on the feedwater quality.
- RO Membrane: Change it as required based on 90 Percent Rejection. The recommended maximum service life is 36 months.

## B. REPLACING THE FILTER CARTRIDGES

The life of the prefilter cartridge generally depends on the local water conditions (i.e., dirt, rust and/or chlorine levels) while the life of the postfilter cartridge(s) is generally determined by the length of service.

### When to Replace the Sediment/Carbon Prefilter Cartridge

- Every six months to one year, based upon your dealer's recommendation and knowledge of the local water conditions.
- A noticeable decrease in water production is an indication that the prefilter requires changing.
- As a rule, private wells require more frequent prefilter changes while softened feed water usually requires only yearly replacement.
- Recommended maximum prefilter service life is one year.

### When to Replace the Carbon Prefilter Cartridge

The prefilter removes free chlorine from the feedwater supply to protect the TFCM membrane from chlorine attack. To find out the chlorine level in a water supply, call the public water supplier.

- Prefilter should be changed every year.

### When to Replace the Carbon Postfilter Cartridge

- If the filter is being used to control tastes and odors, replace it every year.
- If the filter is being used to meet standards for a regulated organic chemical contaminant, then cartridge replacement should be based on a monitoring program established with a public health agency.

### How to Replace the Prefilter and Postfilter Cartridges

- 1) Lift up on the faucet handle to drain the tank. Close the feed-water valve. Wait five (5) minutes for the purification assembly to completely depressurize.
- 2) Twist the filter cartridge 1/4 turn to the left so that the ears on the cartridge are able to disengage from the head. Firmly pull the cartridge from the head. It may be necessary to twist the cartridge slightly from side to side to help free it.
- 3) Remove the new filter cartridge from its sanitary sealed wrapper. (Double check to see that it is the correct replacement by comparing the labels.)
- 4) Using tap water, food grade silicone lubricant or glycerin, wet the o-ring seals to make cartridge insertion easier.
- 5) Line up the cartridge ears, insert the cartridge and push it into the head until it is fully seated. Twist the cartridge 1/4 turn to the right to lock it into place.
- 6) Open the feedwater valve, and carefully check for leaks.
- 7) Flush the filters for a minimum of five minutes.

